

Manufacturing Flow

Steelmaking

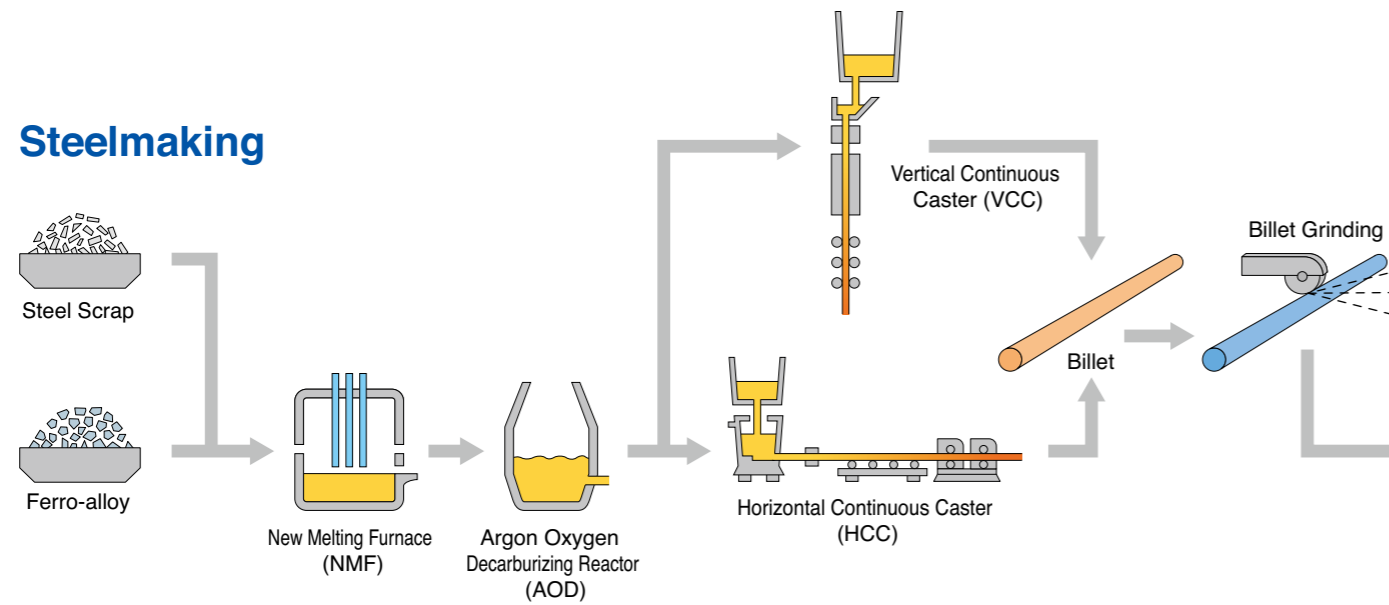

Wire Rod Rolling

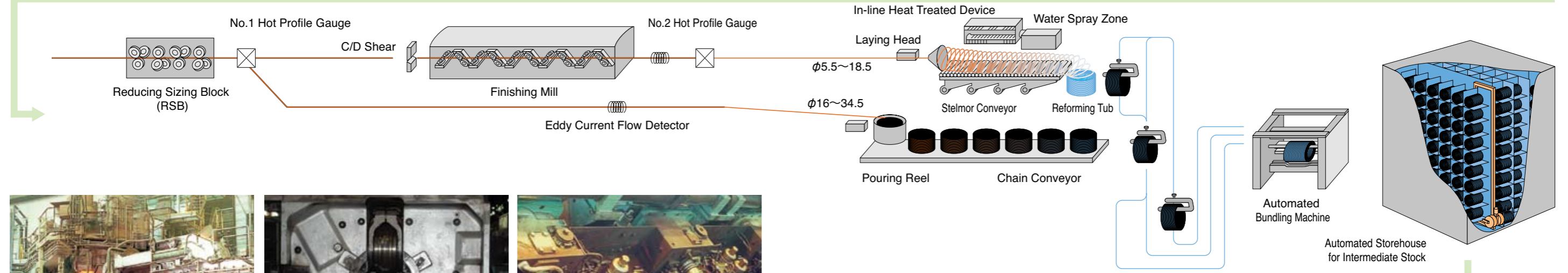
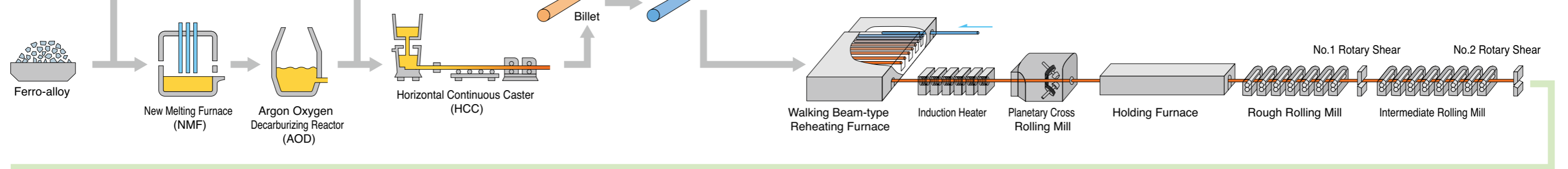

Specialty Wire Rod Finishing

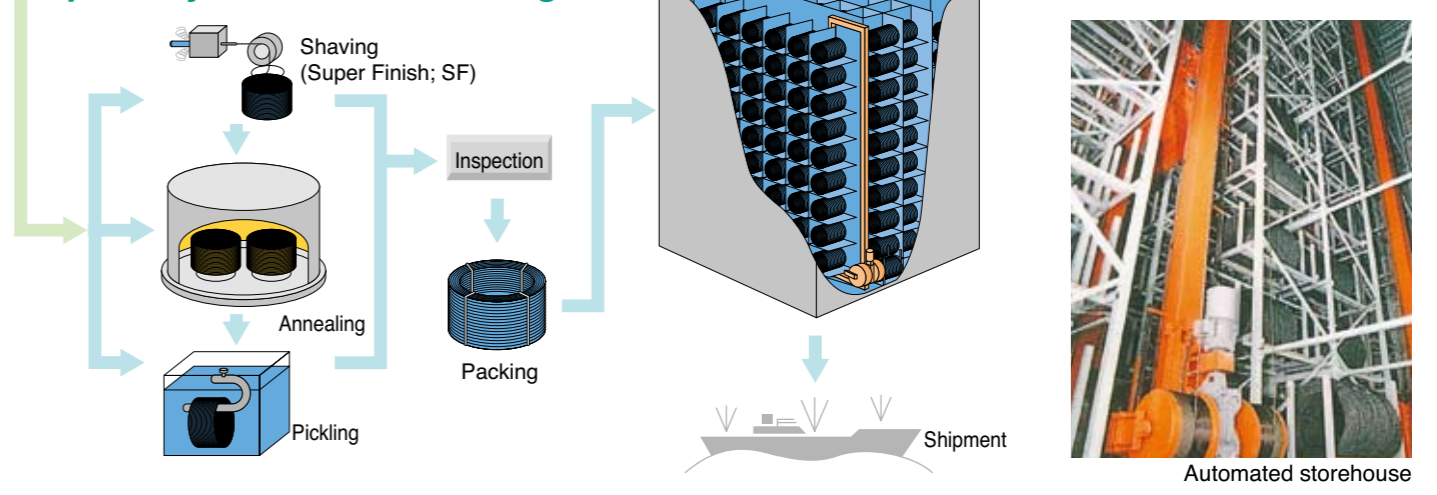

Characteristic Properties and Application Examples by Grades and Type

Martensitic Stainless Steels

- It is an Fe-Cr type alloy stainless steel containing 13%Cr.
- It possesses heat-treatment characteristics similar to those of most alloy steels and demonstrates wide-ranging mechanical properties after appropriate heat treatment.
- This steel grade possesses strong magnetic properties.

Ferritic Stainless Steels

- It is an Fe-Cr alloy steel containing 18% or more Cr. It generates nearly no γ phase at high temperatures and is nearly a ferritic single-phase steel.
- This type of steel does not harden significantly with heat treatment.
- It demonstrates maximum softness, ductility and corrosion resistance in the as-annealed state, and possesses magnetic properties similar to those of martensitic stainless steel.

Austenitic Stainless Steels

- It is an Fe-Cr-Ni alloy steel and its representative type is 18Cr-8Ni steel and is an austenitic single-phase steel non-magnetic in the range from room temperature to high temperature.
- It does not harden with heat treatment.
- Austenitic stainless steel incurs work hardening and work-induced transformation due to cold working, demonstrating wide-ranging mechanical properties and showing magnetism in some cases.
- Austenitic stainless steel is annealed and its precipitation of carbides is restricted through rapid cooling from high temperatures, which enables the steel to demonstrate maximum softness, ductility and corrosion resistance.

Application Examples

Grades	Type No.	Application examples									
		Spring	Small screw	Bolt/nut	Steel mesh	Shaft/pin	Needle	Nail	Rope	Washer	Machining parts
Martensitic	403			○		○					
	410		○			○					
	416					○					○
	420J2					○					
	420F					○					○
	NSSC 550		○	○			○	○			
Ferritic	410L			○							
	430		○		○	○					
	430F										○
	434		○								
	NSSC 160R		○	○	○	○					
	NSSC 180		○	○	○	○					
	NSSC 190				○	○					
Austenitic	201					○	○				
	302	○				○	○				
	303					○					○
	303Cu					○					○
	304	○		○	○	○	○	○	○	○	
	304L		○	○	○						
	304N1					○		○		○	
	304J3			○				○			
	305		○	○							
	305J1		○								
	309S				○						
	310S				○						
	316	○		○	○				○		
	316L				○						
	316C		○	○							
	316F					○					○
	317			○	○						
	317L			○	○						
	321			○	○						
	347			○	○						
XM7		○	○								
NSSC 170					○	○					
NSSC 270R		○	○	○				○			
NSSC 130M	○					○					
NSSC 131						○					
Precipitation-hardening	631J1	○				○					

System Diagram of Stainless Steels

Austenitic Stainless Steels

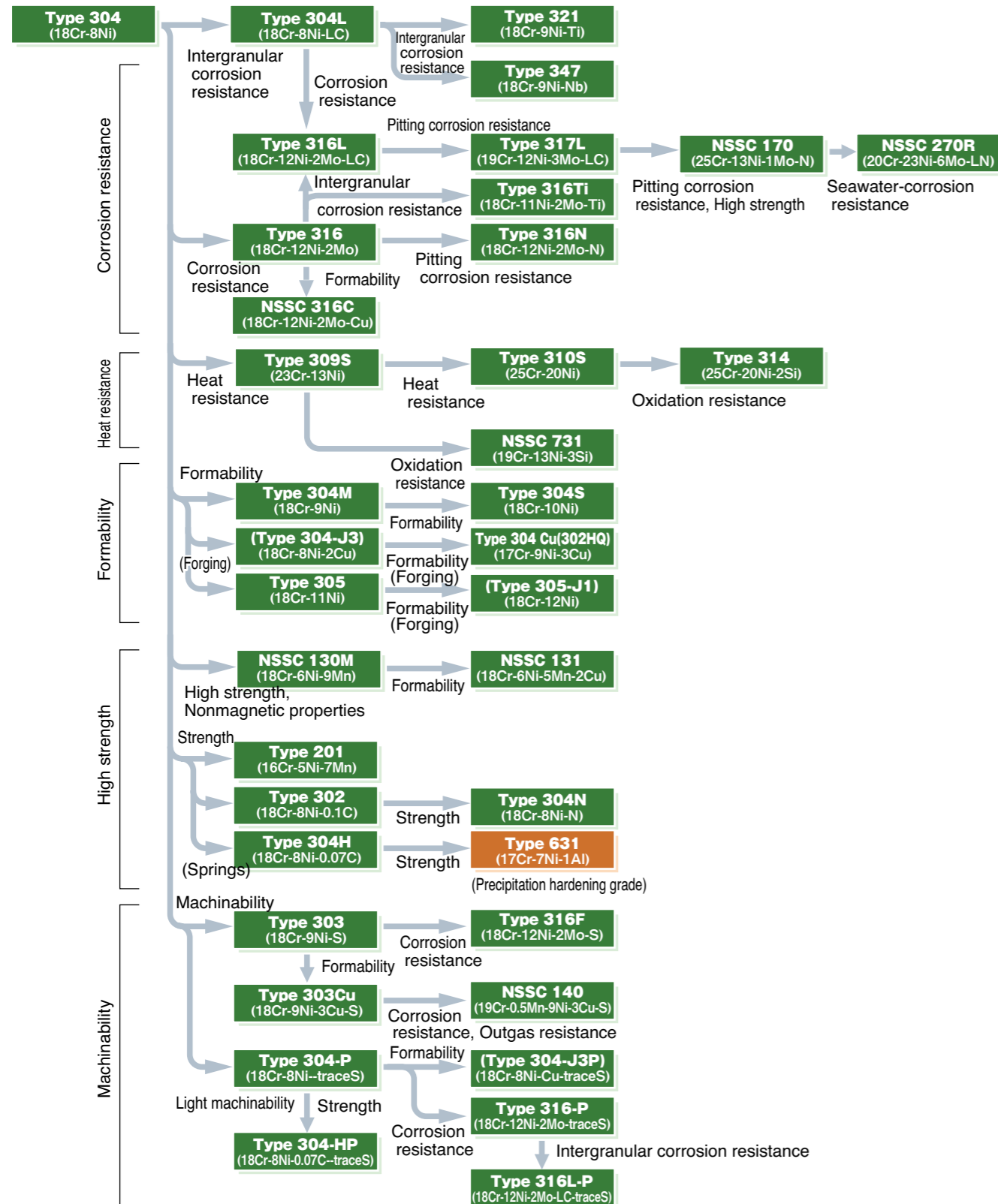

Martensitic Stainless Steels

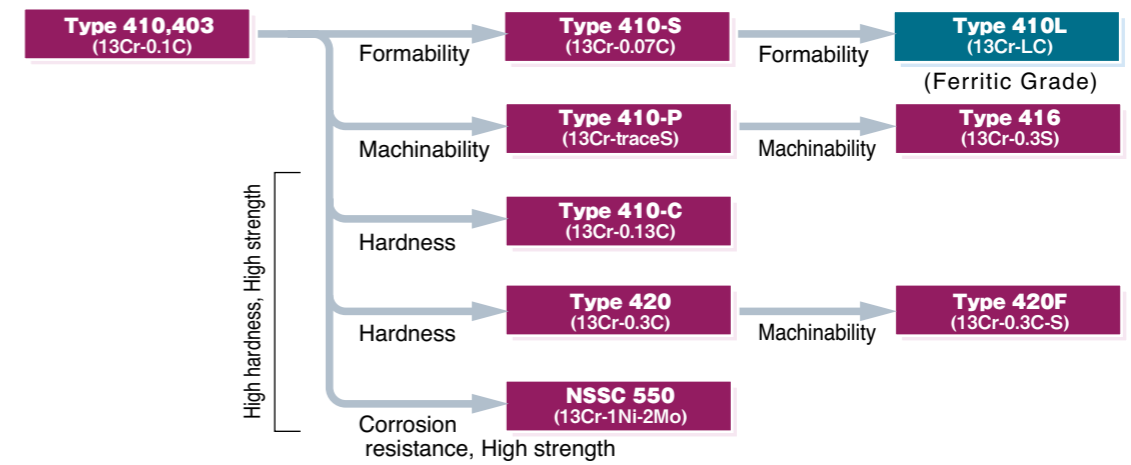

Ferritic Stainless Steels

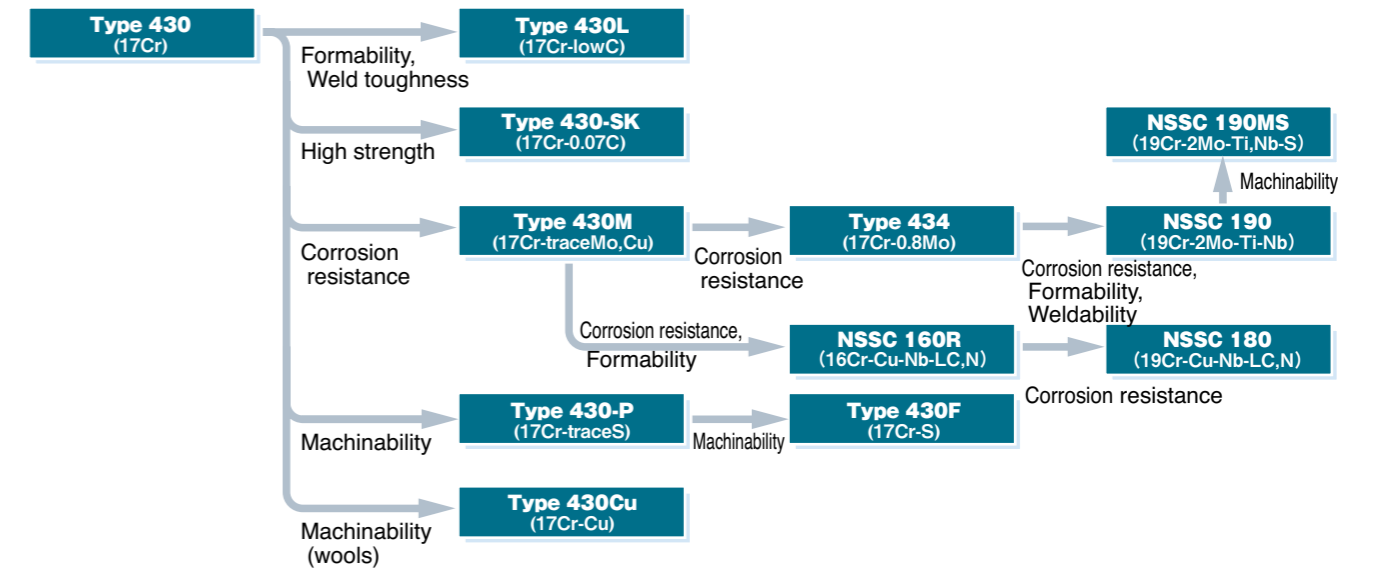

Dual-phase (austenitic-ferritic) Stainless Steels

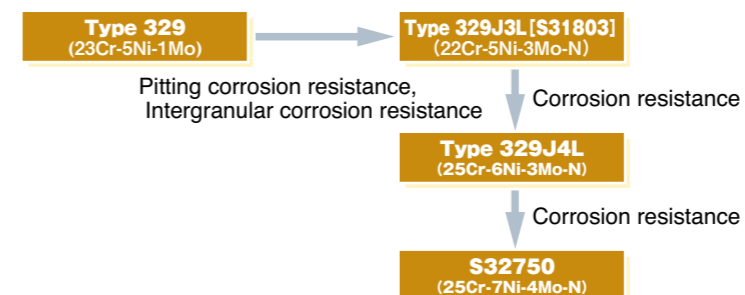

Precipitation Hardening Stainless Steels

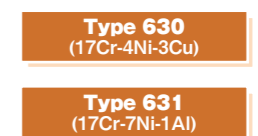

Application Examples

Stainless steel wire rods are used for components of automobiles, aircraft, electric railway cars, ships, rockets, artificial satellites and other indispensable equipments.

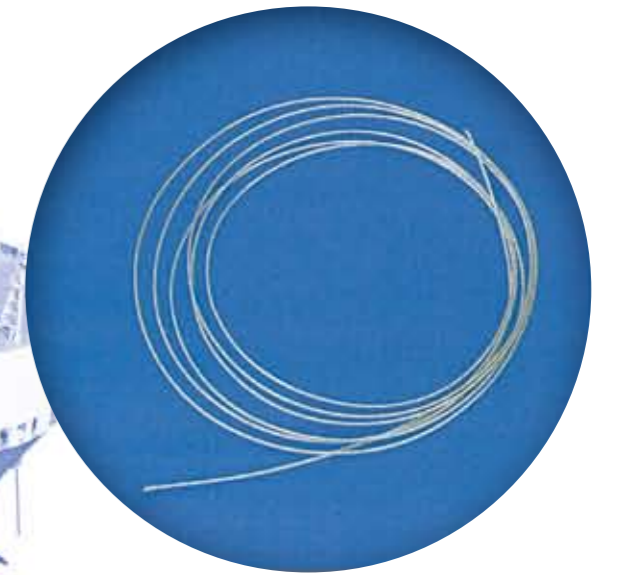
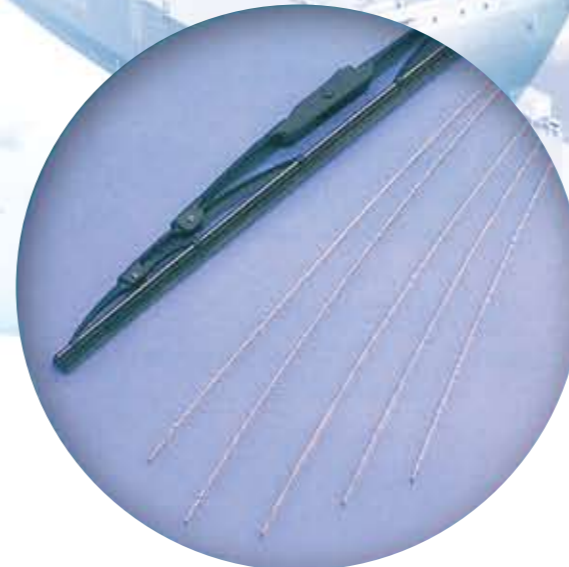

Chemical Composition

Standard Types (Stainless and Heat-resistant Steels)

Grades	AISI Type No. & [UNS No.]	Chemical Composition (%)									
		C	Si	Mn	P	S	Ni	Cr	Mo	Cu	Others
Martensitic	403 [S40300]	≤0.15	≤0.50	≤1.00	≤0.040	≤0.030	≤0.60	11.50/13.00	—	—	—
	410 [S41000]	≤0.15	≤1.00	≤1.00	≤0.040	≤0.030	≤0.60	11.50/13.00	—	—	—
	410S [S41008]	≤0.08	≤1.00	≤1.00	≤0.040	≤0.030	≤0.60	11.50/13.50	—	—	—
	416 [S41600]	≤0.15	≤1.00	≤1.25	≤0.060	≥0.15	≤0.60	12.00/14.00	≤0.60	—	—
	420 [S42000]	0.16/0.25	≤1.00	≤1.00	≤0.040	≤0.030	≤0.60	12.00/14.00	—	—	—
	420F [S42020]	0.26/0.40	≤1.00	≤1.25	≤0.060	≥0.15	≤0.60	12.00/14.00	≤0.60	—	—
Ferritic	410L [—]	≤0.030	≤1.00	≤1.00	≤0.040	≤0.030	≤0.60	11.00/13.50	—	—	—
	430 [S43000]	≤0.12	≤0.75	≤1.00	≤0.040	≤0.030	≤0.60	16.00/18.00	—	—	—
	430F [S43020]	≤0.12	≤1.00	≤1.25	≤0.060	≥0.15	≤0.60	16.00/18.00	≤0.60	—	—
	434 [S43400]	≤0.12	≤1.00	≤1.00	≤0.040	≤0.030	≤0.60	16.00/18.00	0.75/1.25	—	—
Austenitic	201 [S20100]	≤0.15	≤1.00	5.50/7.50	≤0.060	≤0.030	3.50/5.50	16.00/18.00	—	—	N≤0.25
	302 [S30200]	≤0.15	≤1.00	≤2.00	≤0.045	≤0.030	8.00/10.00	17.00/19.00	—	—	—
	303 [S30300]	≤0.15	≤1.00	≤2.00	≤0.20	≥0.15	8.00/10.00	17.00/19.00	≤0.60	—	—
	304 [S30400]	≤0.08	≤1.00	≤2.00	≤0.045	≤0.030	8.00/10.50	18.00/20.00	—	—	—
	304L [S30403]	≤0.030	≤1.00	≤2.00	≤0.045	≤0.030	9.00/13.00	18.00/20.00	—	—	—
	305 [S30500]	≤0.12	≤1.00	≤2.00	≤0.045	≤0.030	10.50/13.00	17.00/19.00	—	—	—
	309S [S30908]	≤0.08	≤1.00	≤2.00	≤0.045	≤0.030	12.00/15.00	22.00/24.00	—	—	—
	310S [S31008]	≤0.08	≤1.50	≤2.00	≤0.045	≤0.030	19.00/22.00	24.00/26.00	—	—	—
	316 [S31600]	≤0.08	≤1.00	≤2.00	≤0.045	≤0.030	10.00/14.00	16.00/18.00	2.00/3.00	—	—
	316L [S31603]	≤0.030	≤1.00	≤2.00	≤0.045	≤0.030	12.00/15.00	16.00/18.00	2.00/3.00	—	—
	316F [S31620]	≤0.08	≤1.00	≤2.00	≤0.045	≥0.10	10.00/14.00	16.00/18.00	2.00/3.00	—	—
	317 [S31700]	≤0.08	≤1.00	≤2.00	≤0.045	≤0.030	11.00/15.00	18.00/20.00	3.00/4.00	—	—
	317L [S31703]	≤0.030	≤1.00	≤2.00	≤0.045	≤0.030	11.00/15.00	18.00/20.00	3.00/4.00	—	—
	904L [N08904]	≤0.020	≤1.00	≤2.00	≤0.045	≤0.030	23.00/28.00	19.00/23.00	4.00/5.00	1.00/2.00	—
	321 [S32100]	≤0.08	≤1.00	≤2.00	≤0.045	≤0.030	9.00/13.00	17.00/19.00	—	—	Ti≥5×C%
	347 [S34700]	≤0.08	≤1.00	≤2.00	≤0.045	≤0.030	9.00/13.00	17.00/19.00	—	—	Nb≥10×C%
	(304CU) (302HQ) [S30430]	≤0.08	≤1.00	≤2.00	≤0.045	≤0.030	8.50/10.50	17.00/19.00	—	3.00/4.00	—
Austenitic-Ferritic	329 [S32900]	≤0.08	≤0.75	≤1.50	≤0.040	≤0.030	2.5/5.0	23.0/28.0	1.0/2.0	—	—
	329J3L [S31803]	≤0.030	≤1.00	≤2.00	≤0.040 (≤0.030)	≤0.030 (≤0.020)	4.50/6.50 (4.5/6.5)	21.00/24.00 (21.0/23.0)	2.50/3.50 (2.5/3.5)	—	N:0.08/0.20
	329J4L [—]	≤0.030	≤1.00	≤1.50	≤0.040	≤0.030	5.50/7.50	24.00/26.00	2.50/3.50	—	N:0.08/0.30
— [S32750]	≤0.030	≤0.80	≤1.20	≤0.035	≤0.020	6.0/8.0	24.0/26.0	3.0/5.0	≤0.50	N:0.24/0.32	
Precipitation-hardening	630 [S17400]	≤0.07	≤1.00	≤1.00	≤0.040	≤0.030	3.00/5.00	16.00/18.00	—	—	Al:0.75/1.50
	631 [S17700]	≤0.09	≤1.00	≤1.00	≤0.040	≤0.030	6.50/7.75	—	—	—	—

For information on other steel types than listed in this table, inquire us.

NSSC Standard

Series and Grades	Type No.	Chemical Composition (%)										
		C	Si	Mn	P	S	Ni	Cr	Mo	Cu	Others	
NSSC series	Martensitic	NSSC 550	0.10/0.20	≤1.00	≤1.00	≤0.040	≤0.010	1.00/2.40	12.50/14.00	1.80/2.30	—	N:0.05/0.15
	Ferritic	NSSC 160R	≤0.02	≤1.00	≤1.00	≤0.040	≤0.006	≤0.60	16.00/18.00	—	0.30/0.60	N≤0.02 Nb:0.30/0.60 Nb/(C+N)≥10
		NSSC 180	≤0.020	≤1.00	≤1.00	≤0.040	≤0.006	≤0.60	19.00/21.00	—	0.30/0.60	Nb≥10×(C+N)
		NSSC 190*1)	≤0.015	≤0.50	≤0.50	≤0.040	≤0.030	—	18.00/20.00	1.75/2.25	—	Ti+Nb≥16×(C+N)
	Austenitic	NSSC 130M*2)	0.07/0.12	≤1.00	9.00/10.00	≤0.030	≤0.030	5.00/6.00	17.00/19.00	—	—	N:0.20/0.35
		NSSC 131	0.01/0.05	≤1.00	3.00/7.00	≤0.040	≤0.030	5.00/6.00	17.00/19.00	—	—	N:0.10/0.30
		NSSC 316C	≤0.08	≤1.00	≤2.00	≤0.045	≤0.030	10.00/14.00	16.00/18.00	2.00/3.00	2.00/4.00	—
		NSSC 170	≤0.06	≤1.50	≤2.00	≤0.040	≤0.030	12.00/16.00	23.00/26.00	0.50/1.20	—	N:0.25/0.40
		NSSC 270R	≤0.020	≤0.80	≤1.00	≤0.030	≤0.015	22.00/23.50	19.00/21.00	5.50/6.50	0.50/1.00	N≤0.05
	NSSC XM7SH	≤0.030	≤1.00	≤2.00	≤0.045	≤0.030	8.50/10.50	17.00/19.00	—	3.00/4.00	—	

Similar steel grade
*1) Type 444
*2) Type 202

Stainless Steel for Welding Application

Grades	AWS Classification	Chemical Composition (%)									
		C	Si	Mn	P	S	Ni	Cr	Mo	Cu	Others
Martensitic	ER410	≤0.12	≤0.50	≤0.60	≤0.030	≤0.030	≤0.60	11.50/13.50	≤0.75	≤0.75	—
	ER420	0.25/0.40	≤0.5	≤0.6	≤0.03	≤0.03	≤0.6	12.0/14.0	≤0.75	≤0.75	—
	ER409Cb	≤0.08	≤1.0	≤0.8	≤0.04	≤0.03	≤0.6	10.5/13.5	≤0.50	≤0.75	Nb≥10×C%
Ferritic	ER430	≤0.10	≤0.50	≤0.60	≤0.030	≤0.030	≤0.60	15.50/17.00	—	—	—
Austenitic	ER308	≤0.08	0.30/0.65	1.00/2.50	≤0.030	≤0.030	9.00/11.00	19.50/22.00	≤0.75	≤0.75	—
	ER308L	≤0.030	0.30/0.65	1.00/2.50	≤0.030	≤0.030	9.00/11.00	19.50/22.00	≤0.75	≤0.75	—
	ER308LSi	≤0.030	0.65/1.00	1.00/2.50	≤0.030	≤0.030	9.00/11.00	19.50/22.00	≤0.75	≤0.75	—
	ER309	≤0.12	0.30/0.65	1.00/2.50	≤0.030	≤0.030	12.00/14.00	23.00/25.00	≤0.75	≤0.75	—
	ER309L	≤0.030	0.30/0.65	1.00/2.50	≤0.030	≤0.030	12.00/14.00	23.00/25.00	≤0.75	≤0.75	—
	ER309LSi	≤0.030	0.65/1.00	1.00/2.50	≤0.030	≤0.030	12.00/14.00	23.00/25.00	≤0.75	≤0.75	—
	ER310	0.08/0.15	0.30/0.65	1.00/2.50	≤0.030	≤0.030	20.00/22.50	25.00/28.00	≤0.75	≤0.75	—
	ER312	≤0.15	0.30/0.65	1.00/2.50	≤0.030	≤0.030	8.00/10.50	28.00/32.00	≤0.75	≤0.75	—
	ER316	≤0.08	0.30/0.65	1.00/2.50	≤0.030	≤0.030	11.00/14.00	18.00/20.00	2.00/3.00	≤0.75	—
	ER316L	≤0.030	0.30/0.65	1.00/2.50	≤0.030	≤0.030	11.00/14.00	18.00/20.00	2.00/3.00	≤0.75	—
	ER316LSi	≤0.030	0.30/0.65	1.00/2.50	≤0.030	≤0.030	11.00/14.00	18.00/20.00	2.00/3.00	≤0.75	—
	ER317	≤0.08	0.30/0.65	1.00/2.50	≤0.030	≤0.030	13.00/15.00	18.50/20.50	3.00/4.00	≤0.75	—
	ER317L	≤0.030	0.30/0.65	1.00/2.50	≤0.030	≤0.030	13.00/15.00	18.50/20.50	3.00/4.00	≤0.75	—
	ER347	≤0.08	0.30/0.65	1.00/2.50	≤0.030	≤0.030	9.00/11.00	19.00/21.50	≤0.75	≤0.75	Nb+Ta≥10×C%
ER307	0.04/0.14	0.30/0.65	3.3/4.75	≤0.03	≤0.03	8.0/10.7	19.5/22.0	0.5/1.5	≤0.75	—	
ER318	≤0.08	0.30/0.65	1.00/2.50	≤0.030	≤0.030	11.0/14.0	18.0/20.0	2.0/3.0	≤0.75	Nb+Ta≥8×C%	
Precipitation-hardening	ER630	≤0.05	≤0.75	0.25/0.75	≤0.030	≤0.030	4.5/5.0	16.0/16.75	≤0.75	3.25/4.00	Nb+Ta: 0.15/0.30

For information on other steel types than listed in this table, please inquire us.

Mechanical Properties

Grades	Type No.	[Reference] Mechanical properties (wire rods after heat treatment)					[Reference] Heat treatment conditions (JIS G 4303)			
		Heat treatment	Tensile strength (N/mm ²)	Elongation (%)	Reduction of area (%)	Hardness (Hv)	Annealing (°C)	Quenching (°C)	Tempering (°C)	Solid-solution treatment (°C)
Martensitic	Type403	Annealing	≤600	≥20	≥55	≤240	800 to 900 slow cooling or approx. 750 rapid cooling	950 to 1,000 oil quenching	700 to 750 rapid cooling	—
	Type410	Annealing	≤600	≥20	≥55	≤240	800 to 900 slow cooling or approx. 750 rapid cooling	950 to 1,000 oil quenching	700 to 750 rapid cooling	—
	Type416	Annealing	≤600	≥20	≥55	≤240	800 to 900 slow cooling or approx. 750 rapid cooling	950 to 1,000 oil quenching	700 to 750 rapid cooling	—
	Type420	Annealing	≤800	≥12	≥40	—	800 to 900 slow cooling or approx. 750 rapid cooling	950 to 980 oil quenching	600 to 750 rapid cooling	—
Ferritic	Type430	Annealing	≤600	≥20	≥50	≤240	780 to 850 air cooling or slow cooling	—	—	—
	Type430F	Annealing	≤600	≥20	≥50	≤240	680 to 820 air cooling or slow cooling	—	—	—
	Type434	Annealing	≤600	≥20	≥60	≤240	780 to 850 air cooling or slow cooling	—	—	—
Austenitic	Type201	Solid-solution treatment	≤900	≥35	≥45	≤330	—	—	—	1,010 to 1,120 rapid cooling
	Type302	Solid-solution treatment	≤700	≥35	≥60	≤330	—	—	—	1,010 to 1,150 rapid cooling
	Type303	Solid-solution treatment	≤700	≥35	≥50	≤270	—	—	—	1,010 to 1,150 rapid cooling
	Type304	Solid-solution treatment	≤700	≥40	≥60	≤260	—	—	—	1,010 to 1,150 rapid cooling
	Type304L	Solid-solution treatment	≤650	≥40	≥60	≤255	—	—	—	1,010 to 1,150 rapid cooling
	Type305	Solid-solution treatment	≤600	≥40	≥60	≤240	—	—	—	1,010 to 1,150 rapid cooling
	Type309S	Solid-solution treatment	≤750	≥40	≥60	≤270	—	—	—	1,030 to 1,150 rapid cooling
	Type310S	Solid-solution treatment	≤650	≥40	≥50	≤255	—	—	—	1,030 to 1,180 rapid cooling
	Type316	Solid-solution treatment	≤650	≥40	≥60	≤255	—	—	—	1,010 to 1,150 rapid cooling
	Type316L	Solid-solution treatment	≤650	≥40	≥60	≤255	—	—	—	1,010 to 1,150 rapid cooling
	Type321	Solid-solution treatment	≤700	≥40	≥50	≤270	—	—	—	920 to 1,150 rapid cooling
	TypeXM7	Solid-solution treatment	≤550	≥40	≥60	≤225	—	—	—	1,010 to 1,150 rapid cooling
Precipitation-hardening	Type631	Solid-solution treatment	≤1050	≥20	≥60	≤315	—	—	—	1,000 to 1,100 rapid cooling

Sizes Available

General Materials

Millimeter size	Inch size (millimeter conversion value)	Reference	Millimeter size	Inch size (millimeter conversion value)	Reference	Millimeter size	Inch size (millimeter conversion value)	Reference
5.5	9/32(5.56)		11.0			18.5		
5.7			11.2		*1)	19.0		
6.0	15/64(5.95)		11.5	29/64(11.51)		19.5		
6.15		*1)	11.9		*1)	20.0		
6.35	1/4(6.35)		12.0	13/32(11.91)		20.5		*1)
6.5			12.3		*1)	21.0	53/64(21.03)	
6.75			12.5			21.5	27/32(21.43)	
7.0			12.7	1/2(12.70)		22.0		
7.3			13.0			22.7		*1)
7.5	19/64(7.54)		13.5			23.0	29/32(23.02)	
8.0	5/16(7.94)		14.0			23.5	59/64(23.42)	
8.1		*1)	14.5		*1)	24.0		
8.3	21/64(8.33)		14.7		*1)	25.0	63/64(25.00)	
8.5			15.0	19/32(15.08)		26.0		
8.7	11/32(8.73)		15.5	39/64(15.48)		26.5		
9.0			15.7		*1)	27.0		
9.5	3/8(9.52)		16.0			28.0		
9.7		*1)	16.3		*1)	30.0		
10.0	25/64(9.92)		16.5			31.0		
10.3		*1)	17.0	43/64(17.07)	*1)	32.0		
10.5			17.5	11/16(17.46)		33.0		
10.7	27/64(10.72)		18.0			34.0		
						34.5		

*1) Because of non-standard size, please consult us when ordering.
FYI, sizes more than φ16 are available at a pitch of 0.1mm.

SF (Super Finish) Materials

Grade	Description
A	An as-rolled size is specified and scalping is performed to assure surface quality.
B	A finished size after scalping is specified.

Basic Diameters in Grade A

Nominal size	A6.0	A6.35	A7.0	A8.0	A8.7	A9.0	A9.5	A10.0	A11.0	A12.0	A13.0	A14.0	A15.0	A16.0	A17.0	A18.0
Basic diameter (at SF-P)	5.4	5.75	6.4	7.4	8.1	8.4	8.9	9.4	10.4	11.4	12.4	13.4	14.4	15.4	16.4	17.4

Notes
1) Actual diameter of A7 is 6.4mm, while actual diameter of B7 is 7.0mm.
2) For Grade B, please consult us when ordering.

Specifications and Bundling of Coil

Coil Specifications

Item	General material		SF material of A6.0 to A18.0	
	5.5mm φ ~18.5mm φ	16.0mm φ ~34.5mm φ		
Coil weight (kg)	Name	1 (ton)	1 (ton)	1 (ton) *1)
	Standard	1,050	1,050	1,000 *1)
	Range	500~1,100 (min.200)	500~1,100 (min.200)	400~1,050*1) (min.150)
Coil size (mm)	Inside diameter	800	870	850
	Outside diameter	1,350	1,250	1,350
	Height (max)	1,200	900	1,200
Direction of coil turn	Clockwise	Clockwise or counterclockwise	Clockwise	

*1) For some austenitic stainless steels, the unit coil weight may become 0.5 (ton). Confirm this in placing an order. [Standard: 500kg, range: 200 to 600 kg (100 kg min.).]

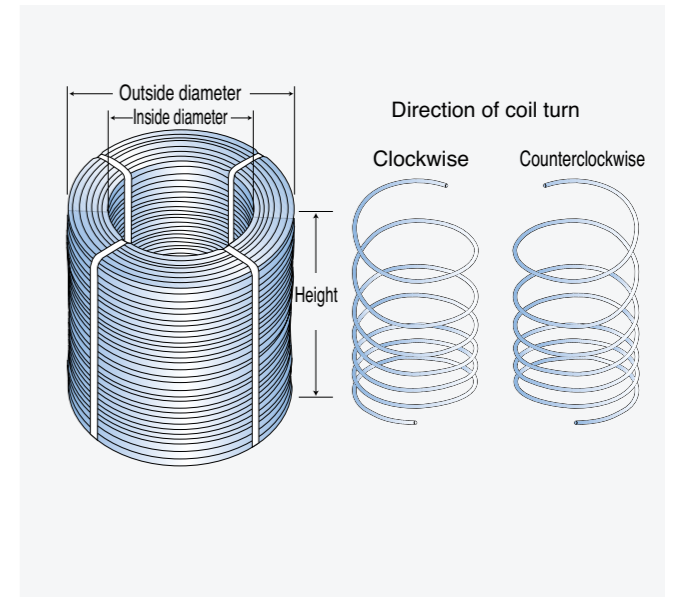

Binding Method

Material	Hoop (resin or iron)
Number of hoops	4



Coil Shape and Marking

[Unpacked coil] Marking label (one label each on the inner and outer surfaces)

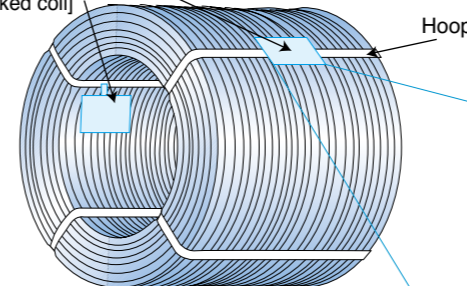

[Packaged coil]

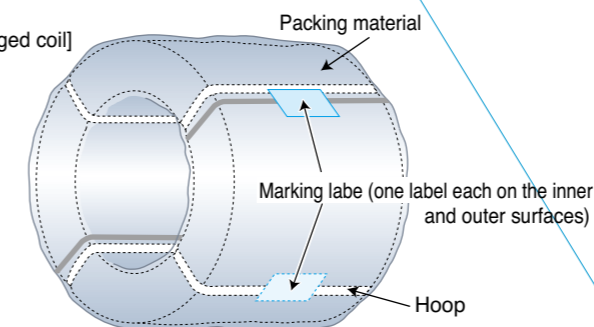

Example of marking

(Customer's Name)	
Specification	AISI304
Size	7.00
Heat Treatment	ST
Heat No.	E12345
LOT	1-10-111-01-0-0
Prod Month	11-10
Weight	1,000kg
Nippon Steel & Sumikin Stainless Steel Corp. HIKARI WORKS/Made in Japan	
SAMPLE	

MEMO
